

Designed, engineered, and manufactured in our facility located in Le Center, Minnesota, equipped with modern engineering, fabrication and assembly capabilities.

Rugged Design

Engineered and built tough with powder coat paint galvanealed steel.

Full Load Tested

Every generator is 100% load tested in-house.

Vanguard Industrial Engine

Premium-grade Vanguard engines are application-engineered to power equipment that works for a living.



VOLTAGE	POWER FACTOR	STARTING WATTS	STARTING AMPS @ 240V	RUNNING WATTS	RUNNING AMPS @ 120	RUNNING AMPS @ 240V
120/240 1-PH	1.0	19,000	79	17,000	142	71

MOTOR STARTING (CODE G)	5 HP
DBA @ 7 METERS FULL LOAD	78
TOTAL HARMONIC DISTORTION	< 6%
MAIN CIRCUIT BREAKER 120/240 1-PH	70A 240V
BONDED NEUTRAL	YES

ASSEMBLED IN	USA
EPA APPROVED	YES
CARB APPROVED	NO
TÜV CERTIFICATION CSA	YES
UNIT WARRANTY ⁽¹⁾	2 YEARS COMMERCIAL

PANEL

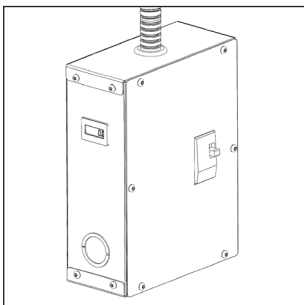

ENGINE

ENGINE BRAND	BRIGGS & STRATTON
ENGINE MODEL	VANGUARD 61
ENGINE STARTER	ELECTRIC
ENGINE SPEED	3600 RPM
ENGINE CYLINDERS	V-TWIN
ENGINE HP	33
FREQUENCY	60 HZ
FREQUENCY REGULATION	+/- 3%

IGNITION SYSTEM	ELECTRONIC
LUBRICATION	FULL-PRESSURE
BORE/STROKE	85.6 mm x 86.6 mm
DISPLACEMENT/TYPE	993CC/ OHV
LOW OIL PROTECTION	STANDARD
RECOMMENDED OIL ⁽²⁾	5W-30 SAE
OIL CAPACITY	2.4 QT
COMPRESSION RATIO	8.2:1

FUEL

FUEL CONSUMPTION	
100%	2.3 GAL/HR
75%	2.1 GAL/HR
50%	1.6 GAL/HR
25%	1.1 GAL/HR

DERATES

ABOVE SEA LEVEL 1,000 FT	3%
ABOVE 77°	1% FOR EACH 10°F

GENERATOR END

GENERATOR END BRAND	LINZ
GENERATOR END MODEL	E1C13M D/2
LEAD	4
VOLTAGE REGULATION	CAPACITOR +/- 5%
TEMPERATURE RISE	125/40°C
BRUSH	YES
SPEED	3600 RPM
STATOR	2/3 PITCH
WINDINGS	100% COPPER
STATOR WINDING	DOUBLE LAYER CONCENTRIC
BEARINGS	SINGLE (MAINTENANCE FREE)
EFFICIENCY PEAK	81%
INSULATION	CLASS H
INGRESS PROTECTION	IP23

SHIPPING

SHIPPING DIMENSIONS (L x W x H)	44" x 28" x 32.5"
SHIP WEIGHT	450 LBS
FREIGHT CLASS	70

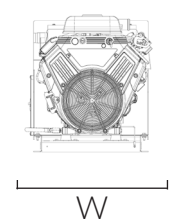
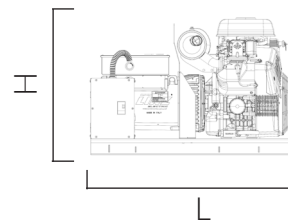

OPTIONAL ACCESSORIES

15 GALLON FUEL TANK	19022-400
FUEL TANK WALL MOUNT KIT	19022-401
MAINTENANCE KIT	16200-011
BATTERY	BCI GROUP 26 500 CCA

NOTES:

(1) For more warranty information, see operator's manual.

(2) The recommended oil is for normal applications.

See operator's manual for more oil recommendations.

Specifications are subject to change without notice.



Sales: 507-357-6821

Service: 507-357-6831

